



MAPLE "A" NEWS

Newsletter of the Green Mountain Chapter/Region of M.A.F.C.A. and M.A.R.C. Inc.

1968 *Our Forty First Year* 2009

Volume 37, Issue #4 July August, 2009



See Us On The Web
www.vtmodelaford.org

SPEAKIN "A" SPOKES and howdy folks.

Congrats to a deserving friend of all of us Peter Crosby, our faithful news letter editor on his

recent certificate from MARC. He has always made the Maple "A" News informative and most of all fun. I presented it to him at the May meet at Celine DeChatlets.

After the meet and eat we took a tour to a good friends Antique Farm Museum of Fred Webster. He has allot of very interesting collectables. A nice gentle man almost ninety and building an actual stage coach out of cherry wood with no plans from scratch. A sight to behold! Then on to my residence across the lake from Celine's for a prognosis of what is wrong with Maggie. Celine and I bought the 31 Tudor a few years ago from John Aldous.

Well, June is here ... no heat bill, and the economy is slowly returning to something better.

Good news from me to you all, my nine year restoration a 1930 Pickup is running and insured and registered. It's on third base and needs allot more. The lady at the Motor vehicle Dept. told me to get it inspected. I told her it did not need to be, as it is old enough not to. I guess we need to clear this up. She said only if the plates say antique, I talked to members, some say yes some say no. Well, any way, I drove miss Lu Lu Bell down to Jeffersonville, VT. to Paul and Vicki's meet. I named the truck after Don Poutre's old cracker story in the previous Newsletters.

Celine and I found the perfect storm when we hit Troy coming home. We had water coming in everywhere but thanks to Rain -X on the windshield we kept going even though about six or so modern cars were parked waiting it out ha ha ha.

The problem with the thirty one Tudor .. Maggie ... a blown head gasket! It ran real good ... on two cylinders. Vice Pres. Paul Boozan drove all the way up to my place and said Well.. lets pull the head. Lesson learned I have to keep checking the head for tightness. Find a parade have fun on the Forth.

Happy chugg-in Doug Leithead

FREE MAFCA MEMBERSHIP

Special promotional free MAFCA membership. See application on page 4. This is only open to Model "A" Ford Enthusiasts that are not a member of the Model "A" Ford Club of America. Membership includes a subscription to "The Restorer". For more information go to the web site www.mafca.com.

Support your interest and your hobby.

What	August Meeting / Picnic
When	August 16, 2009 11 o'clock AM
Where	Richard & Gail Phinney 66 Featherbed Lane South Hero, VT 05486
Lunch	Bring a salad or dessert to share. Hot dogs and burgers provided.
Questions	Phone 802-372-5230 modelafan@myfairpoint.net Please RSVP! We need a head count.
Activity	Possible seminar, and check out Dick's projects.



The Grapevine

The grapevine is news about our fellow members, Please let us know when your birthdays' and anniversaries are so they can be included. Contact Peter Crosby at 802-878-6376.

July Birthdays

Bruce Boozan July 13

Bob Davis July 25

August Birthdays

Doug Leithead August 26

Anniversary

Charles & Erma Haselton

60th on August 20



Blowing My Horn

Peter Crosby, Editor

Find on Page 3 the law adopted in 2004, regarding the State of Vermont vehicle inspection law. If you **have** "antique or exhibition plates" and your car conforms with the other rules you do not have to have your "A" Vermont State Inspected. I hope this clears up any questions or concerns.

I also want to put everyone on notice that the September and October Newsletter will be late. Pam and I will be moving around that time and we will be settling into our new home. Please keep the Newsletter content coming in.

Treasurer's Report

Dick Phinney

Ending Balance-checking..... \$1029.78

Ending Balance-savings \$1676.06

Charity Fund.....\$0.00

06/27/09

2009 Activities

Paul Boozan

It is never too early to start thinking about the 2009 meet schedule. If you would like to host a meet this year please let me know so you can be included in our Spring, Summer and Fall activities. My phone number is 802-644-5688.

August 2, 2009	Cars of Yesteryear Car Show	North Country Union HS Newport, Vt
August 7-9, 2009	52nd Stowe Car Show	Stowe, VT www.vtauto.org/carshows.php
August 16, 2009	GMC Meet South Hero, VT	Richard & Gail Phinney
Sept. 18-20, 2009	43rd Bennington Car Show	Pownell, VT www.bennington.com/attractions/events/carshow.html
Sept. 25—27, 2009	New England Model "A" Meet	Laconia, NH www.NEMeet2009.com
Sept. 27, 2009, 11:00 AM	GMC Meet	Bruce & Kathy Boozan, South Burlington, VT



Vice President Paul Boozan looks over a hand tool collection at Fred Webster's farm in May, during the GMC meet in Coventry, VT. See page 6 for more photos. Photos by Peter Crosby

1222. INSPECTION OF REGISTERED VEHICLES

(a) Except for school buses which shall be inspected as prescribed in section 1282 of this title and motor buses as defined in section subdivision 4(17) of this title which shall be inspected twice during the calendar year at six-month intervals, all motor vehicles registered in this state shall be inspected once each year. Any motor vehicle, trailer or semi-trailer not currently inspected in this state shall be inspected within 15 days from the date of its registration in the state of Vermont. The inspections shall be made at garages or qualified service stations, designated by the commissioner as inspection stations, for the purpose of determining whether those motor vehicles are properly equipped and maintained in good mechanical condition. The charges for such inspections made by garages or qualified service stations designated to conduct periodic inspections shall be subject to the approval of the commissioner.

(b) If a fee is charged for inspection, it shall be based upon the hourly rate charged by each official inspection station or it may be a flat rate fee and, in either instance, the fee shall be prominently posted and displayed beside the official inspection station certificate. A person shall not operate a motor vehicle unless it has been inspected as required by this section and has a valid certification of inspection affixed to it. The month of next inspection for all motor vehicles shall be shown on the current inspection certificate affixed to the vehicle.

(c) Notwithstanding the provisions of subsection (a) of this section, an exhibition vehicle of model year 1940 or before, registered as prescribed in section 373 of this title, shall be exempt from inspection; provided, however, the vehicle must be equipped as originally manufactured, must be in good mechanical condition, and must meet the applicable standards of the inspection manual.

Chapter Flea Market

Wanted: 1929 Model "A" Radiator and Shell. Please call Howard Vanderhoof 274 Marble Island Road, Colchester, VT. Phone 802-862-4319

For Sale: 19 inch Wheels, bell housings, Front bumper, flywheels and flywheel housings. Will take offers. Douglas Leithead;1856 Darling Hill Road; Newport, VT 05855 Phone 802-334-2584

FOR SALE: FORD PICKUP TRUCK, 1932/1934 CAB AND BODY, 1929 ENGINE RUNS, NEEDS TIRES, NO RUST, BRAND NEW BRAKES, NOT FOR RESTORING.....JUST FOR FUN DRIVING. \$6,900 OR BEST OFFER. BARBARA CARTER, 802-862-802, SOUTH BURLINGTON, VT

For Sale: 1929 Model "A" Ford Closed Cab Pickup Great driver. \$9,000. Betty Ransford, 237 McConnell Rd., Brandon, VT 05733 - phone 802-247-5457.

Tech Tip

Submitted by Ted Kuchta

Removal of front spring perches

The front spring perches mounted in the front axle can be a very stubborn part to remove and a method that works very well is to make a press using some Model A parts. It involves using the two front spring U bolts (part # A5-455B) and the front spring center lower plate (part # A5-458). Remove the nut that fastens the perch in place. Place a U bolt on the axle on each side of the front wishbone and position the dimple in the spring plate over the threaded part of the spring perch. The U bolt must have good threads because this will require a lot of force and rusted or pitted threads will strip easily before the perch budges from its resting place. Non castle type nuts are recommended because they provide more thread coverage and load bearing ability. Tighten the four nuts on the U bolts uniformly. This applies pressure to push the perch out of the axle. If this does not move the perch, heat may be needed to help loosen the bond of rust. This procedure works well even when the front axle is still on the car.

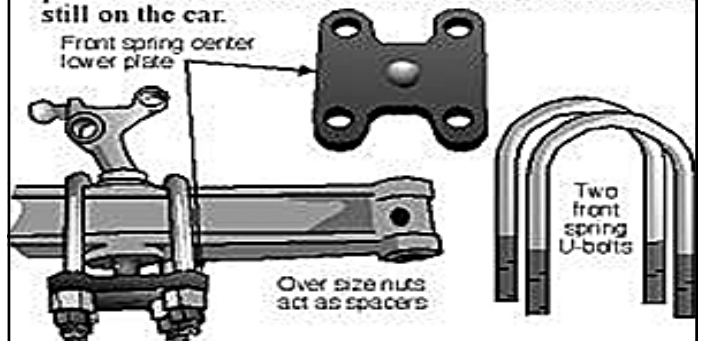



Best Of Show! Bruce & Kathy Boozan proving how original Model "A" Fords can compete in the world of 30's and 40's hot rods, they took best of show for the years 1930 thru 1949 with their authentically restored 1930 Model "A" Ford Closed Cab Pickup at Libby's Dinner in Colchester, VT (benefit the Ronald McDonald house) on June 20th. Photo by Bruce Boozan.

APPLICATION - 2009 Promotional Free Membership

Name _____

Spouses Name _____

Address _____

City _____ State/Prov _____ Zip/Postal _____

Country _____ Phone () _____ - _____

1216 / J:
GREEN MOUNTAIN
PAUL BOOZAN
1364 STEBBINS RD
JEFFERSONVILLE, VT 05464

Mail To: **MAFCA**
250 South Cypress
LaHabra, CA 90631-5586

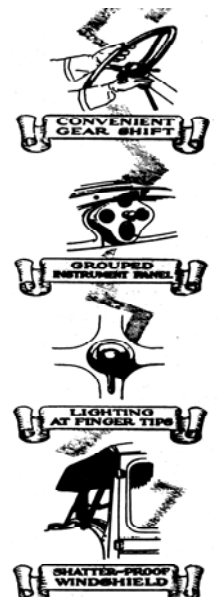

Feb 2009



MODEL "A" MISHAPS

By Doug Leithead



The Two Dollar Tire

I was getting in some wood the other day, recovering from a broken nose and the memory of \$4.35 gallon gas prices, when I was visited by a recollection. One thing I've always noticed about a Model "A" Ford is that it has a ghostly soul. I'm not sure if these rigs really want to run or maybe their previous owners are invisible and are having a blast messing with us.

My good friend Marcel Guilette and I got our cars fixed up enough to attempt the up-coming bicentennial '76 parade in Derby, VT. I had three or four questionable wheels but only three cracked riverside tires. Norm Lawson a previous farmer boss sold for two dollars what looked like a brand new tire and very rusty wheel that lived in a foot of mud since 1938 perhaps. Some people just can't give you anything. Aw ... how about 2 dollars? And I had that much?

That afternoon I put a new 19 inch Ford Ferguson tractor inner tube in the old tire and blew her up with a confident smile. My friend Marcel and I were kicking up some dust on his back road and testing our traction in deep mud holes. You know dodging cow pies out in the pasture, these cars will never embarrass you because their waiting for a better chance to redden your face ... Like a 1976 parade in a few days.

My tire had me bragging to everybody what a great deal I got on it for just two dollars! Marcel had a rear main leaking about quart per parade we calculated. Just put a couple extra quarts in the back seat, when the parades done just put some more oil in her...we never had a big problem.

Another hot Fourth of July and all the parade vehicle participants were snaked around the little driveways in the Derby cemetery. Surprisingly there were about fifteen Model "A"s. Where the heck did all these come from? The wives were getting drunk on coffee brandy and milk ... probably worried about all the eyes of the million people at the big parade. Marcel and I, we didn't care.

Hey the cars are moving! Boy I hope she starts...hah ... just barely. Looking behind ... yup ... Marcel is running! Oh man this is goanna be fun! Chug a chug a chug. Push the clutch push the break and repeat this till your left leg is wiped out. Somewhere about half way in the height of my stress and this affair, I heard someone say, "Hey you're losing your wheel". When I gave a gander at the front driver side, sure enough with each revolution it made itself visible at the top edge of my freshly painted fender. Oh well am I going to hold up the whole parade? Nope... keep going. Now my face was so red! My cheeks were bulging hot with all the extra blood my fast beating heart was mustering up. When I looked back, Marcel looked almost as bad. Oh no! What's his problem?

With all these comments from people on my left side and weird looks at my stupid wheel, we were finally coming to the end. My wife kept saying I should have drunk more! I should have never agreed to this! I can't believe I agreed to this!

Well we made it to the finish line. Marcel and I were recovering from this test of our endurance with a few cold ones. My oil was leaking worse than ever said my big friend and everyone kept saying hey you're losing your oil. Like I can do something about that in the middle of the "expletive" parade! You think you had it bad? Everyone kept saying hey you're losing your wheel!

Marcel pulled on the top of the wheel and looked at the lugs you're not losing a wheel! We checked all four and all seemed tight what the heck?? Oh well, we headed to our homes.

On the way back to my house my 2 dollar tire warped it rotten self right off the rim. It sounded like an old steel wheelbarrow wheel rolling down the road. When I found the tire it was still inflated. It was tired like my left leg. I drove real slow and it still came off again three more times in about two miles before we pulled in our drive way. The parade started at eleven that morning Marcel and his Wife were doing chores by the time we got home. I can do a figure eight with my lips when I'm trying to explain what this tire was doing. The two dollar very rotten tire, Humph!! Just flat on the bottom!





Left: our host Fred Webster from Coventry, VT shows off the progress he made with his stage coach he is building. Above: Fred shows off one of his not so small engines.



Left: Long shot of a 200 foot barn full of collectables. Above: President Doug Leithead sits on a 1929 Ford "A" doodlebug tractor.



Above: Got Milk Cans? If not Fred has them. Right: The Boozan Brothers Bruce and Paul look at Fred's 1923 Ford Model "T" touring.





Club Officers

President-Douglas Leithead; 1856 Darling Hill Road; Newport, VT 05855 Phone 802-334-2584

Vice President-Paul Boozan 1364 Stebbins Rd.; Jeffersonville, VT 05464; Phone 802-644-5688; pboozan@myfairpoint.net

Treasurer-Dick Phinney; 66 Featherbed Lane; South Hero, VT 05486; Phone 802-372-5230; modelafan@myfairpoint.net

Secretary- Bob Davis; 49 Dakin Road, Ferrisburgh, VT 05456; Phone 802-425-7766; charbob@gmavt.net

Region Director-Rod Dolliver; 430 Dolliver Rd.; Charlotte, VT 05445 Phone 802-425-2745; rcdbjd46@aol.com

Newsletter, Webmaster-Peter Crosby; 61 Pearl Street, Unit 40; Essex Junction, VT 05452 Phone 802-878-6376; peter.crosby@myfairpoint.net

Chapter Flea Market

- ◆ Send description of items for the Flea Market to Peter Crosby via mail or Email to peter.crosby@myfairpoint.net.
- ◆ Items should be described For Sale, trade, wanted, or take it away.
- ◆ For Sale items must be listed with asking price.
- ◆ Flea market is open to all members free of charge for auto and fashion related items only.

The Green Mountain Chapter / Region M.A.F.C.A. & M.A.R.C. Inc. is a tax exempt organization under the 501 (c) (7) of the Internal Revenue Code. Federal Employer Identification Number: 30-0357749



MAPLE "A" NEWS

Green Mountain Region / Chapter
MARC / MAFCA Inc.
Peter Crosby, Editor
61 Pearl Street, Unit 40
Essex Junction, VT 05452